



**IN GROUND RESIDENTIAL
ROBOTIC SWIMMING POOL CLEANER
OPERATOR'S MANUAL &
TROUBLESHOOTING GUIDE**

Please Read Carefully Before Using Your Pool Cleaner

ENGLISH

PART # 820332

DO NOT RETURN TO DEALER

Contact Aqua Products dedicated support personnel toll-free at (800) 845-4856 for live assistance or via e-mail at CustomerService@AquaProducts.com for personal support and answers to any questions regarding technical or operating issues of your cleaner.

The following specifications are for the cleaner models - AQUABOT XTREME

POOL TYPE APPLICATION: All residential pool types; Covers floor and lower portion of walls.

DIRECTIONAL GUIDANCE MECHANISM: Features the patented Cable Float

This device turns your cleaner on the floor (rather than the wall), limiting wasteful wall time and providing more attention to the floor, where the majority of the debris resides. This offers faster, more efficient and complete coverage of virtually any pool configuration, while extending the life of your cleaner. Your cleaner will move across the floor, reach the side wall, tilt 90° and climb for a couple of seconds and then reverses to about the pool's midpoint and stops. Its internal pump will then turn off and it will drive in reverse, allowing its Cable Float to lift that side of your cleaner while its opposing side maintains contact with the floor, resulting in an a pivot. The pump will then turn back on and your cleaner will continue back to the wall and complete this sequence three times. On the fourth time, your cleaner will continue to drive across the entire width of the pool, climb the opposing wall for a few seconds, reverse and repeat this entire sequence throughout its operation.

POWER SUPPLY: No Timer or Remote Control

To operate your cleaner simply plug the Power Supply into a properly grounded outdoor (GFCI / R.C.D) outlet and the cleaner's Floating Cord into the Power Supply. Press the ON / OFF switch on the Power Supply upwards to ON. Your cleaner is now working. Note that your cleaner will automatically shut off after 4 hours of operation. To restart; Turn your Power Supply's ON/OFF switch to OFF, wait 30 seconds and then press ON, that's it!

FILTRATION: Includes One Fine Filter Bag.

BOTTOM LID ASSEMBLY: Features the next generation Bottom Lid Assembly

Does not include NeverStuck™ Rollers or Variable Port Extensions, which are available for purchase through your Aqua Products Authorized Dealer or online at www.AquaProducts.com



WARNING! ONLY plug your cleaner into a Ground Fault Circuit Interrupter (GFCI) / Residual Current Device (R.C.D) protected outlet to prevent possible shock or death! ALWAYS keep your Power Supply at least 12' / 3m from the pool's edge as your Power Supply is water resistant, NOT waterproof!



IMPORTANT! This model does NOT climb to waterline! It utilizes the patented Cable Float directional guidance mechanism to cover all pool configurations without climbing to the waterline and therefore has NO Floating Handle!



IMPORTANT! NEVER lift your cleaner out of the water or carry it outside the pool by its Floating Cable as this will cause damage to the Cable internally requiring costly repair! Always hold and carry your cleaner by its side Handles!



IMPORTANT! ALWAYS unplug the Floating Cable from its Power Supply when removing your cleaner from the pool to protect your cleaner from harmful, unwanted potential out-of-water operation due to power surges or unintentional start up, which would cause severe damage to your motor's seals, requiring costly motor replacement!



IMPORTANT! ALTHOUGH a Filter Bag may appear clean it is capable of microfiltering particles 20 times smaller than what the naked eye can see! It is crucial to thoroughly clean the Bag with each use to ensure its ability to properly clean and for your cleaner to consistently have adequate suction and water flow to cover your entire pool! As your pool has a great amount of surface area and water volume to be micro filtered it may take several uses and Bag cleanings until your cleaner is able to maintain your pool without frequent Bag cleanings prior to completion of its suggested cleaning cycle (up to 3 hours).

To view the latest information for your cleaner, such as troubleshooting videos, updated Operator Manuals, eco-efficient savings tips and more visit us online anytime at AquaProducts.com

TABLE OF CONTENTS

Operating Features	3-4
Quick Start Instructions	5
Setting Up Your Cleaner	6-7
Setting up the Power Supply	6
Cleaner Start Position	6
Directional Guidance	7
Maintaining Your Pool Cleaner	8-14
Cleaning and Changing the Filter Bag	8
Flotation	9
Propeller Care	10
Floating Cable Care	10
Scrubbing Brushes Care & Replacement	10-11
Changing Drive Tracks	11
Changing Drive Belts	12-13
Cleaner Storage	14
Preparing Your Cleaner for Shipping	14-15
Troubleshooting Guide (Summary)	16-17
Troubleshooting Guide (In Depth)	18-21



WARNING: *Never operate your cleaner when it is not totally submersed in the pool water! Doing so will void warranty and may cause severe damage to motors and require costly repairs!*



WARNING: *Never allow anyone to swim in the pool while the cleaner is in the pool!*



WARNING: *Using the Floating Cable to lift the cleaner out of the water will cause severe damage to your cleaner and may result in costly repair!*



WARNING: *The Power Supply must be at least 12 feet / 4 meters from the pool's edge at all times!*



WARNING! *A Ground Fault Circuit Interrupter (GFCI) / Residual Current Device (R.C.D), must be installed to protect your electric outlet and to prevent and possible electrical shock!*

OPERATING FEATURES

Although the shape and color of cleaners and components featured herein may not be identical to those of your cleaner, their operating and service procedures are. **The reference numbers below are used throughout this manual.**

Figure 1

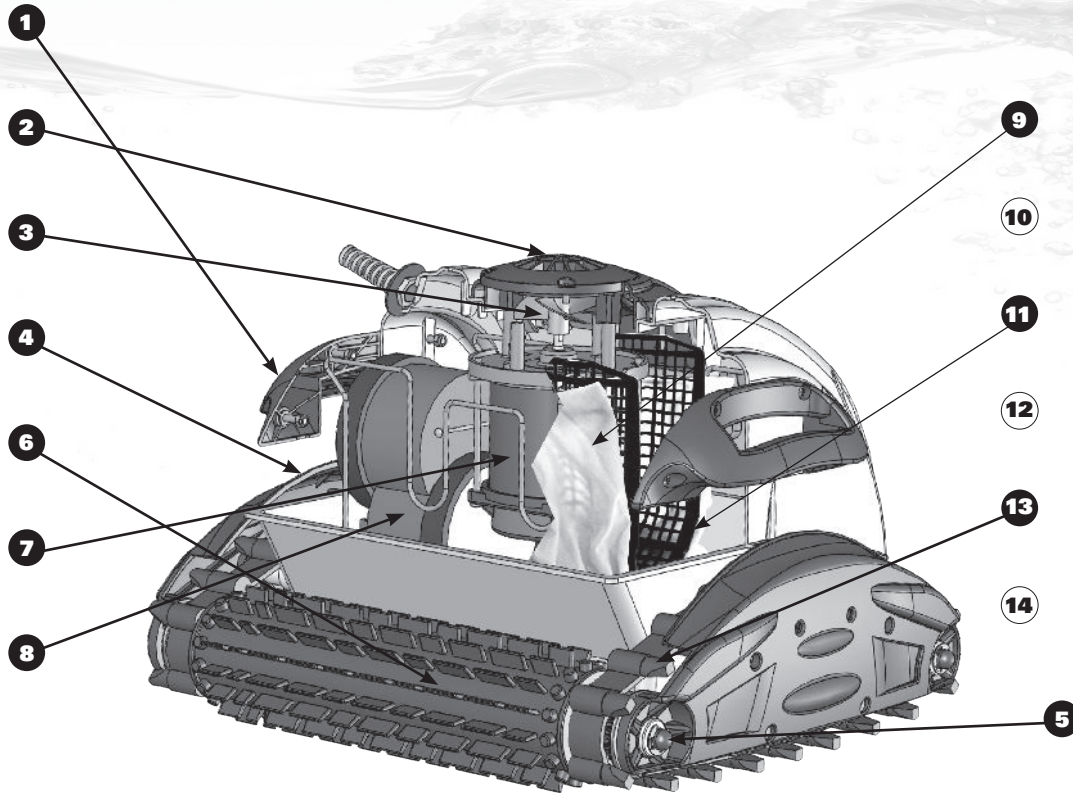

- | | | |
|------------------------------|--------------------------------------|--------------------------------|
| 1. Side Handle | 6. Brushes | 11. Filter Screen |
| 2. Outlet Top | 7. Pump Motor | 12. Floating Cable (SEE BELOW) |
| 3. Propeller | 8. Drive Motor | 13. G-Tooth™ Drive Track |
| 4. Side Plate | 9. Filter Bag | 14. Wheel Tube |
| 5. Wheel Tube Retaining Ring | 10. Bottom Lid Assembly (SEE PAGE 4) | |

FLOATING CABLE FEATURES

Figure 2

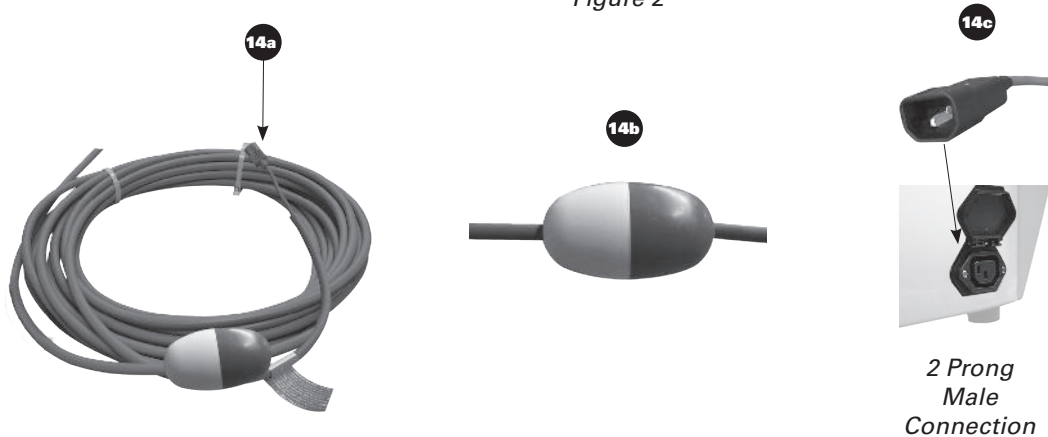

- 14a. Floating Cable
- 14b. Cable Float
- 14c. Cable Float (2 PRONG MALE CONNECTION)

BOTTOM LID ASSEMBLY

Figure 3

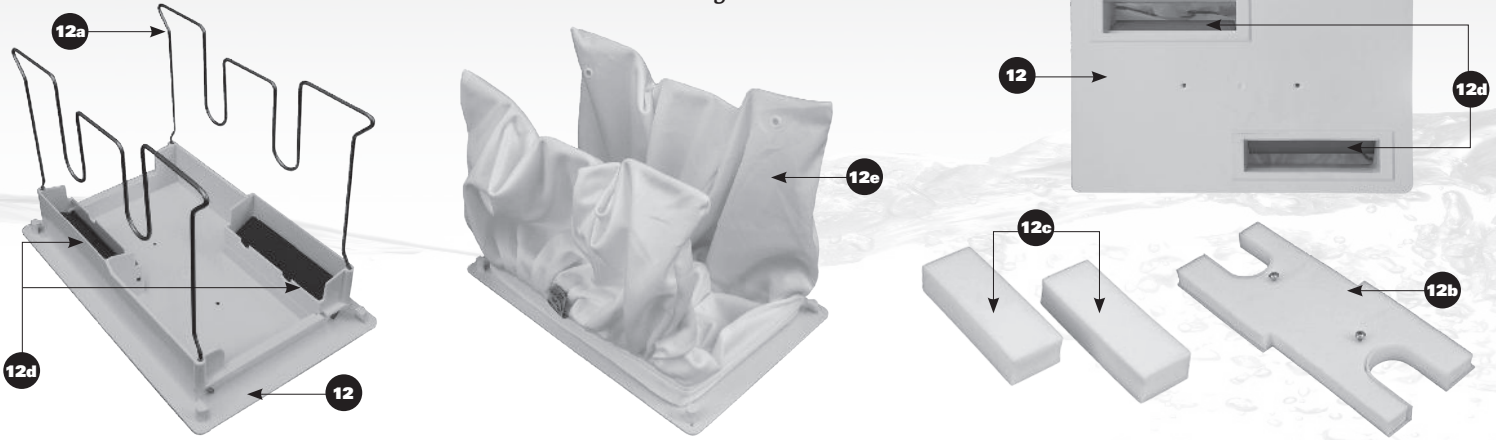

- 12. Bottom Lid
- 12a. Wire Frame Bag Support
- 12b. "H" - Float (Fig. 3a)
- 12c. Side Pocket Floats (Fig. 3a)
- 12d. Debris Intake Port Flap
- 12e. Filter Bag

POWER SUPPLY FEATURES

Figure 4

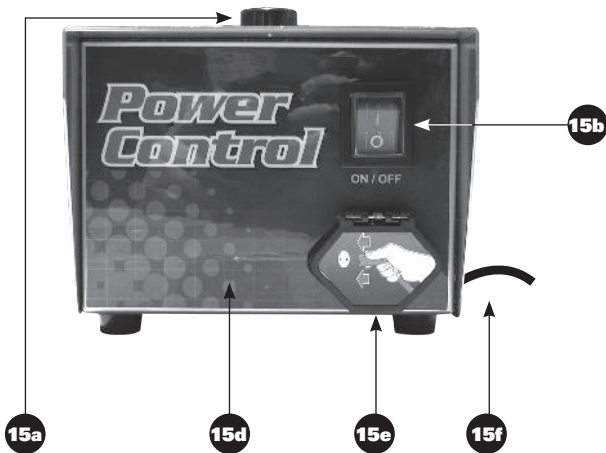

- 15a. Power Supply Handle
- 15b. Power Switch - ON/OFF
- 15c. Fuse Holder*
- 15d. Power Supply (Housing)
- 15e. Floating Cable Socket
- 15f. Power Supply Cable

* Fuse Holder is located on the back of the Power Supply

QUICK START INSTRUCTIONS

SETTING UP YOUR NEW ROBOTIC POOL CLEANER IS AS EASY AS 1, 2, 3!



TIP! To help protect your Floating Cable from potentially getting wrapped around your cleaner's brushes, it is suggested to turn off your pool's filtration system while your cleaner is in operation.

Figure 5a



2

Make sure that the Power Supply is positioned at the center of the long side of the pool that that the cleaner enters at the pool at its midpoint.

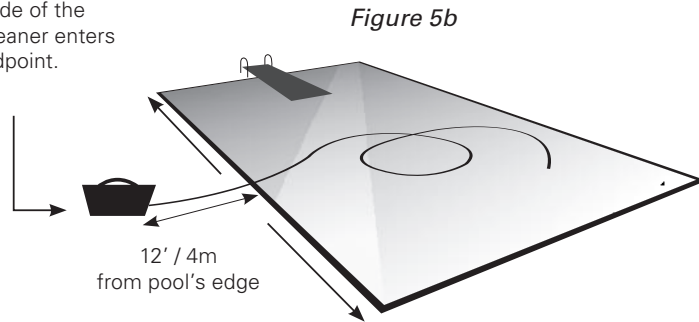

WARNING: The Power Supply must be placed at least 12 feet / 4 meters from the pool's edge!

3



NOTE: It is suggested to unplug the Power Supply when the cleaner is not in use.

Press the Switch to ON to start your cleaner.



WARNING: A Ground Fault Circuit Interrupter (GFCI) / Residual Current Device (R.C.D.) must be installed to protect your electric outlet and to prevent any possible electrical shock!

SETTING UP YOUR ROBOTIC POOL CLEANER



WARNING: The Power Supply must be placed at least 12 feet / 4 meters from the pool's edge at all times!



WARNING: A Ground Fault Circuit Interrupter (GFCI) / Residual Current Device (R.C.D.) must be installed to protect your electric outlet and to prevent any possible electrical shock!

1. SETTING UP THE POWER SUPPLY

The Power Supply (Fig. 4) should be placed in a sheltered area, **at least twelve (12) feet / four (4) meters away from the pool at all times** (Fig 6a). While the Power Supply is weather-resistant, it is **not waterproof** and therefore **should be placed in an elevated dry area where it will not be allowed to sit in puddles of water**. Less is More: For optimum cleaning performance locate the Power Supply

at the mid-point of your pool's longest side (Fig. 6b). This will allow your cleaner to make the best use of its length of Floating Cable without using excess Cable length. Excess Cable in the pool may result in it unnecessarily twisting, kinking or getting entangled within your cleaner's rotating scrubbing Brush system. Excess Cable should be kept coiled outside the pool near the Power Supply.

Plug the Power Supply Cord into a standard Ground Fault Circuit Interrupted (GFCI) / Residual Current Device (R.C.D.) protected outlet. If your GFCI outlet is too far away and your cleaner does not have enough Cable to properly enter the pool at the midpoint of its longest side then you may use a proper outdoor grounded extension cord, but always keep the Power Supply at least 12' / 4 m from the pool's edge!



TIP! To help protect your Cable from potentially getting twisted, it is suggested to turn off your pool's filtration system while your cleaner is in operation to reduce the pool's filter circulation effect that may push and circulate the Cable.

NOTE: It is suggested to unplug your Power Supply when not in use to prevent accidental starts!

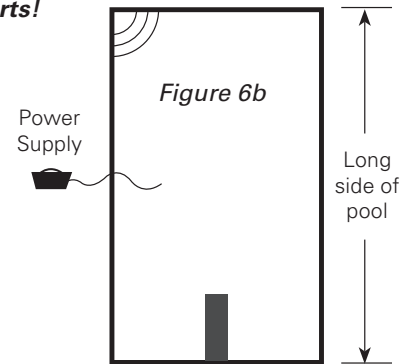
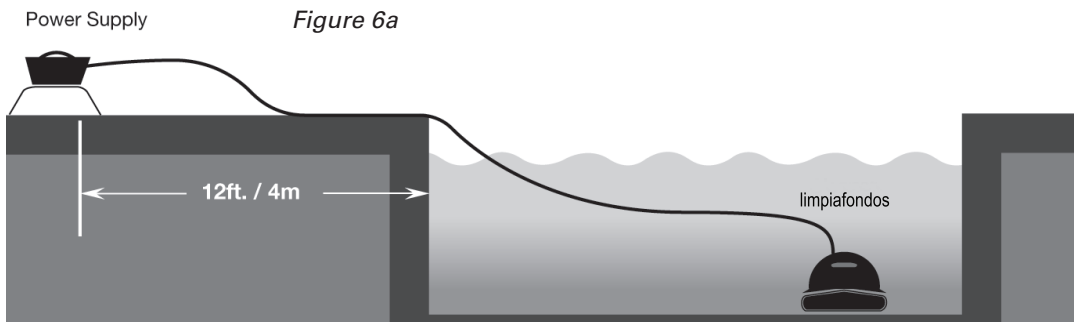

2. CLEANER START POSITION

1. Holding the Handle, submerge your cleaner upside down, and gently rock it back and forth under the water to allow any trapped air to escape, which is critical for proper balancing or it may not clean and cover your pool as designed.
2. While submerged turn upright, then let go allowing your cleaner to settle to a level area on the pool floor near the shallow end. Starting it on an incline (like a deep end hopper) may cause the cleaner, program and sensors to mistakenly consider the incline as the floor, and conversly on the floor as a wall. This would offset its cleaning program and coverage, resulting in missed areas. Be sure to start the cleaner on a level surface every time.
3. Turn ON Power Supply to begin cleaning.

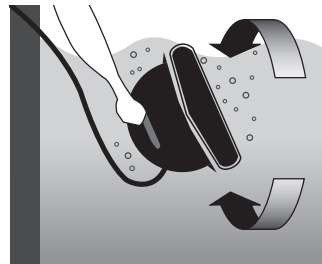

DIRECTIONAL GUIDANCE

CABLE FLOAT

The Cable Float (Fig. 2) is a flotation device that enables your cleaner to turn on the floor where the majority of debris resides. This offers faster, more efficient and complete coverage of virtually any pool configuration. Your cleaner will move down the wall and about halfway across the pool floor and then reverse. When it reverses its internal Pump Motor will temporarily turn off allowing the Cable Float to lift its side of the cleaner allowing only the opposing side to have traction. As the cleaner reverses, the side with traction will cause your cleaner to turn in an arc-radius manner. The internal Pump will turn back on and full traction will be regained, allowing the cleaner to continue in a straight line to the wall.

CLEANING PATTERN

Cable Float

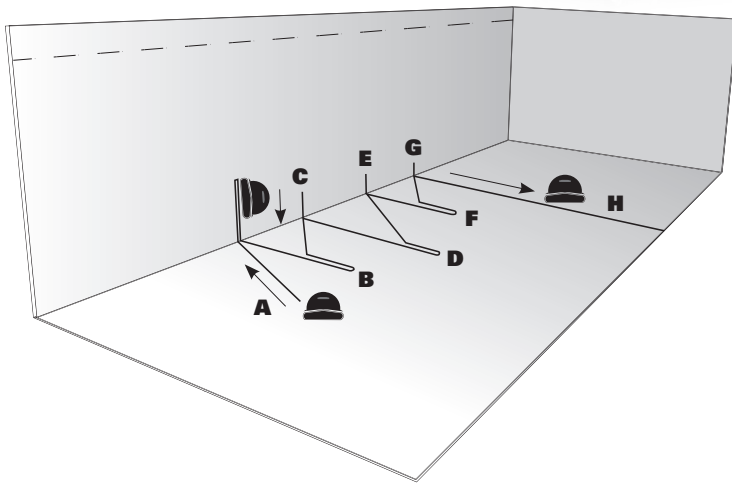
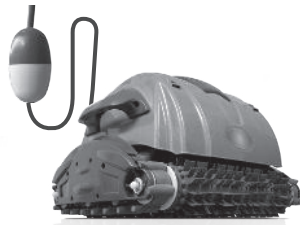

Pattern Description:

- A. Your cleaner searches for the wall and climbs it for a couple of seconds reaching only about 1.5' / .5m or so.
- B. Your Cleaner moves across the floor to about half the width of the pool and then reverses backwards for a few seconds. The cleaner turns slightly and moves towards the wall again.
- C. Your cleaner climbs the wall for a couple of seconds.
- D. Your cleaner reverses to move back across the floor to about half the width of the pool and then reverses backwards for a few seconds. The cleaner turns slightly and moves towards the wall again.
- E. Your cleaner climbs the wall for a couple of seconds.
- F. Your cleaner moves across the floor to about half the width of the pool and then reverses backwards for a few seconds. The cleaner turns slightly and moves towards the wall again.
- G. Your cleaner climbs the wall for a couple of seconds.
- H. Your cleaner moves to the opposite wall to restart the full pattern.

NOTE: Your robot is equipped with a safety feature that automatically reverses it after a number of minutes should it not locate a wall and tilt to approximately 90°. This protects your cleaner should it encounter the underside of a ladder for example and be unable to climb.

MAINTAINING YOUR POOL CLEANER

CLEANING AND CHANGING THE FILTER BAG

Thoroughly cleaning the Filter Bag (see step 4 below) after every use is the most important maintenance step you can take to ensure optimum performance of your cleaner. The Filter Bag's (Page 4, Fig. 3) holding capacity is large in comparison to all other brands of independent pool cleaners, but far smaller than that of a pool's main filter. Perhaps it is more important to know that your cleaner's Filter Bag can filter out particles down to 20 times smaller than what many main filters can. This means that the fine particles such as algae and bacteria, invisible to the naked eye, which slip through the main filter and back into the pool to settle into the pores of the pool's surface, will be scrubbed loose and vacuumed up by your cleaner and retained in its Filter Bag. Therefore, although you may see only a fine coating of dirt, the Filter Bag itself may be deeply saturated with ultra fine particulate matter from your pool's large surface area and the flow of water through it becomes restricted and suction is reduced. This will result in remaining dirt and debris not being completely removed from the pool.

Also, strong water flow is required to force the cleaner against the wall when climbing. A dirty Filter Bag weighs the cleaner down, making it hard for your cleaner to climb due to the added weight and reduced water flow. *This lack of climbing may limit your cleaner's ability to cover the entire pool and pick up any more dirt.* Therefore, it is important to clean the Filter Bag thoroughly (see step 4 below) with every use so that the fine particles that get trapped within the fibers of the Filter Bag are removed.

To Clean The Filter Bag:

1. Unplug the Power Supply (Fig. 7a).
2. If your cleaner is in the pool, gently pull it toward you using the Floating Cable (Fig. 7b) until the Handle is within reach. Use the Handle (not the Floating Cable) to slowly pull your cleaner out of the pool after allowing most of the water to drain from your cleaner back into the pool.



IMPORTANT: Using the Floating Cable to lift the cleaner out of the water will cause severe damage to your cleaner and may result in costly repair!

3. Lay your cleaner on its back or side on a soft surface to avoid scratching it. Individually pull each Lock Tab gently away from your cleaner's body to free the Bottom Lid (Fig. 8).
4. Remove the Filter Bag from the Wire Frame Bag Supports (Fig. 9a), turn it inside out and with a high pressure garden hose, wash off all the dirt from the inside out or dunk it in a clean bucket of water and wring the Bag continuously until the rinse water is clear. If necessary, you may machine wash (Gentle Cycle / Cold Water only) the Bag with **NO DETERGENT**. You may re-install the bag immediately or allow it to air dry (never iron or machine dry the Filter Bag).
5. Re-install the Bag on the Wire Frames of the Bottom Lid Assembly, making sure that the "felt" (soft) side of the Fine Filter Bag is facing in. To ensure a proper fit of the Filter Bag onto the Bottom Lid Assembly, locate the Small Label near the Filter Bag's elastic bottom. Position the Filter Bag so that the Small Label is at the center of either long side of the Bottom Lid (Fig. 9a). Then pull the elastic bottom over each Wire (Fig. 9b) and slide the Filter Bag down along the Wires until the Bag reaches the Bottom Lid. At that point the Filter Bag's elastic bottom should be stretched over the plastic ridges located at the base of the Bottom Lid. This holds the Filter Bag in place. Pull the Filter Bag corners to the top corners of the Wire Frame and pull the extra Bag material from each corner inwards along the top center of the Wire Frames (Fig. 9b).
6. Re-install the Bottom Lid Assembly into the bottom of your cleaner. Be sure that the Filter Bag's fabric is not interfering with the locking of the Lock Tabs and that you clearly hear each Tab lock shut.

Figure 7a

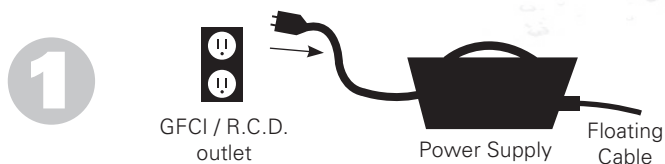

Figure 7b

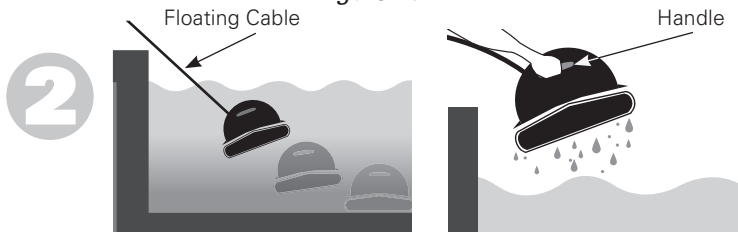

Figure 8

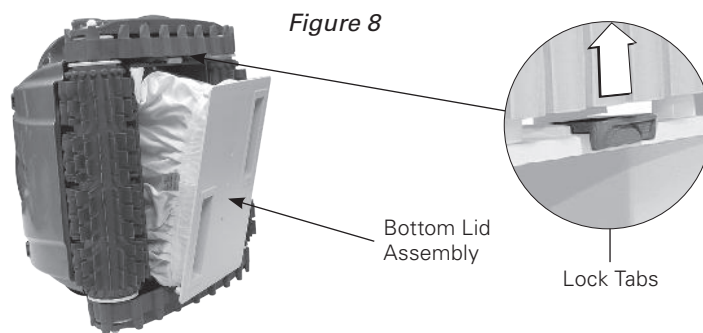
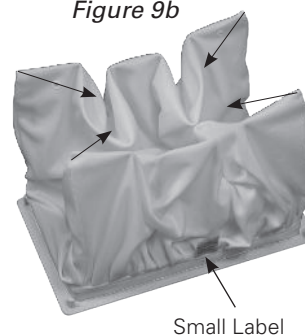

Figure 9a



Figure 9b



IMPORTANT: Although a Filter Bag may appear clean it is capable of microfiltering out particulates 20 times smaller than what the naked eye can see! It is crucial to thoroughly clean the Bag with each use to ensure its ability to properly cover and clean your pool!

FLOTATION

Your cleaner is a universal pool cleaner which performs under varying chemical and temperature conditions in your pool. Your cleaner offers the best possible performance when it is virtually weightless in your pool. Therefore, careful balancing of its weight is important for proper operation. Generally, a new cleaner is universally balanced when used for the first time and additional Flotation (Fig. 10a-b) is not required on start-up.



IMPORTANT: Careful removal of air trapped in the housing is critical. Each time you place your cleaner in the pool use the Handle (while submerged) to turn it upside down and gently rock it back and forth to allow any possible trapped air to escape (See Page 6, #2)!

In some instances the pool environment (e.g. temperature, chemicals, water, etc.) may offset your cleaner's natural buoyancy. Therefore, flotation devices (Fig. 10a-b) have been included in the packaging with your new cleaner to assist its buoyancy.

Adding Flotation on Bottom Lid Assembly (Fig. 11a-b):

1. Remove the Filter Bag. Then place the "H"-Float (Fig. 10a), foam side down, against the inside base of the Bottom Lid Assembly (Fig. 11a). Secure the "H"-Float with the 2 screws provided by fastening them in from the outside of (from under) the Bottom Lid Assembly. This should provide adequate buoyancy.
2. Should your cleaner require more Flotation, then add the 2 remaining Side Pocket Floats (Fig. 10b), 1 at a time until adequate buoyancy is achieved. Pocket Floats do not require any screws or glue. Simply place them into the open rectangular areas **next to** the Debris Intake Port Flaps (Fig. 11b).

Figure 10a



Figure 10b



Figure 11a

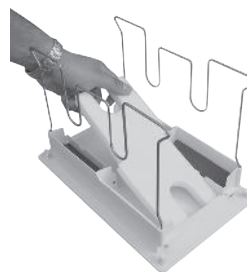
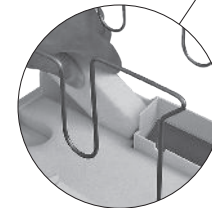
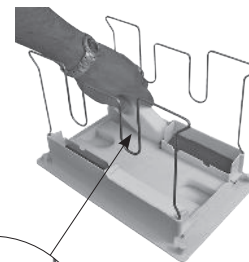

Figure 11b



IMPORTANT: Temperature and chemical composition changes can greatly affect the buoyancy of your cleaner! Therefore, if you have previously installed Flotation devices in your cleaner to assist its buoyancy, it may be necessary to remove the devices one-by-one until proper buoyancy is restored!

PROPELLER CARE

It is a good practice to inspect the Propeller (Page 3; Fig. 1) once or twice per season to check for obstructions, which may reduce water flow and thus vacuuming ability and pool coverage.



IMPORTANT: To protect against personal injury and damage to your cleaner always unplug your cleaner from its Power Supply prior to performing any maintenance or repair procedures!

1. First unplug the cleaner from the Power Supply (Fig. 12a).
2. Then remove the Screws that secure the Outlet Top to the body (Fig. 12b-c). The Outlet Top has 4 Screws. Using a screwdriver or similar instrument, not your finger, turn the Propeller to check that it spins freely and inspect the Propeller for clogs: hair, twigs or other debris, which may keep it from spinning freely. Remove any accumulated material and replace the Outer Top.



IMPORTANT: Be careful not to over-tighten the Screws or you may "strip" the screw holes or crack the Outlet Top when re-assembling!

FLOATING CABLE CARE

Occasionally you should stretch the Floating Cable (Page 3; Fig. 2) out to its full length to prevent a memory from forming and ensure your Cable will not impede your cleaner from reaching all areas of your pool. At that time you should also check the Floating Cable for external damage. Continual rubbing against sharp or rough surfaces may abrade the Floating Cable resulting in damage and possible short-circuiting your cleaner. Animal bites may puncture or fray the cable as well. For these reasons it is important to periodically inspect the Floating Cable.



IMPORTANT: Never lift your cleaner out of the pool using the Floating Cable! Your may use the Floating Cable to pull the cleaner to the side of the pool, but always use the Handle to remove it from the pool (See Page 8, Fig. 7b)! Using the Floating Cable to remove the cleaner from the pool will result in internal connections being broken and costly damage being caused to your cleaner! (See Page 8, Fig. 7b)

SCRUBBING BRUSHES CARE AND REPLACEMENT

Your cleaner's Scrubbing Brushes provide traction and give it the ability to loosen debris. It is important that you not let the Brushes get worn down otherwise your cleaner may lose the ability to scrub, climb, turn and move to clean and cover all areas of the pool. Eventually you will need to change the Brushes on your cleaner. When they need replacement will depend upon how often you use your cleaner and upon the conditions of your pool. High chemical concentrations and rough surfaces will cause faster Brush wear. We recommend that you inspect Brushes frequently to check for excessive wear.

NOTE: Super Brushes stiffen in water less than 70°F which may lessen their ability to climb pool walls.

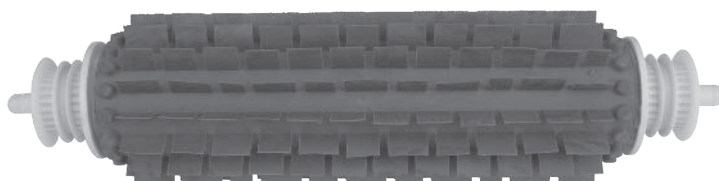

Super Brush

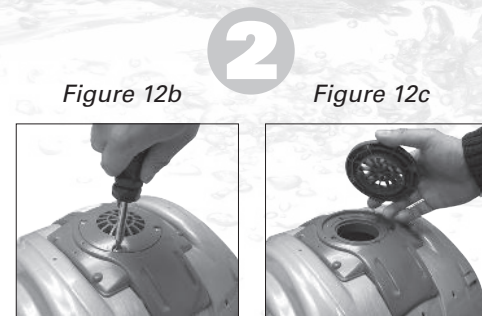
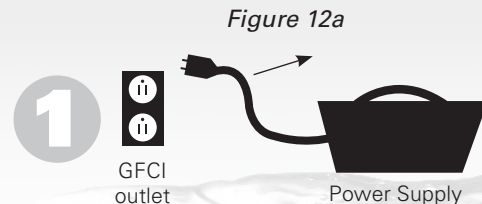



To protect against personal injury and damage to your cleaner always unplug your cleaner from its Power Supply prior to performing any maintenance or repair procedures!

To Change Super Brushes for full length and “split” Wheel Tubes: (Fig. 13)

1. Using a pair of pliers, grab one end of the stainless steel Rod that is securing the old Brushes onto the Wheel Tube. Pull away from the Wheel Tube slowly until the entire existing Brush is freed and removed (Fig. 13).
2. Wrap the new Super Brush around the Wheel Tube.
3. Join the ends of the replacement Super Brush using the Metal Rod supplied in the package. Slide the Rod through the Tabs molded into the ends of the Brush (Fig. 13). Make sure that the Rod is inserted through every Tab.

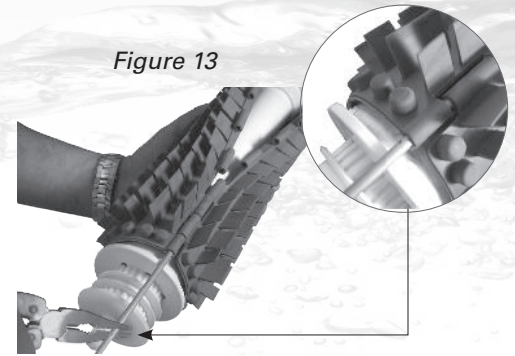

Figure 13



TIP! Lubricate the Rod with soapy water and use a pair of pliers to hold the Rod to make it easier to insert.



TIP! Leave Super Brushes in direct sunlight to warm up before mounting. They will be more pliable and easier to work with.

CHANGING DRIVE TRACKS

Drive Tracks (Fig. 14) may become worn over the normal course of use and will require replacement based on the frequency of use, the pool’s chemical balance, pool surface and length of season. Worn (stretched, loose or “flat-spotted”) Drive Tracks may effect the cleaning pattern impeding its ability to cover the entire pool. If during your periodic inspection you find that your Drive Tracks are worn, please contact your *Authorized Dealer for replacement Drive Tracks* .

1. Unplug your cleaner from its Power Supply and remove your cleaner from the pool.
2. Place your cleaner on its side, on a soft surface which will not scratch the Body’s finish.
3. With your thumbs pushing against the Side Plate (Fig. 15), hook your fingers under the Drive Track and pull it toward the Side Plate. When you get the Drive Track over the “lip” of the Side Plate, hold it there with one hand, and with the other hand, grip the Wheel Tube (Fig. 15) and rotate it away from the cleaner until the Drive Track “walks” over the Side Plate. Continue this until the Drive Track is free.
4. To mount the new Track, hook it around the lower Wheel Tube end and pull it upward as you guide it between the cleaner’s Body and Side Plate.
5. Push inward on the Drive Track and force it over the edge of the Side Plate. Rotate the Wheel Tube, towards you, until the Drive Track properly seats itself on the Wheel Tube between the Side Plate and the cleaner’s body
6. Repeat steps 1 through 5 with the Drive Track on the other side of the cleaner.

Figure 14



G-Tooth™
Drive Track

Figure 15





IMPORTANT: Always replace both Tracks at the same time! Replacing only one will adversely effect the cleaner's cleaning pattern!

CHANGING DRIVE BELTS

Drive Belts (Page 13; Fig. 19a-b) may become worn over the normal course of use and will require replacement based on the frequency of use, the pool's chemical balance and length of season. Worn Drive Belts will impede your cleaner's ability to move or climb and may effect the cleaning pattern impeding its ability to cover the entire pool. If during your periodic inspection you find that your Drive Belts are stretched, loose or "flat-spotted" please contact your *Authorized Dealer* for replacement Drive Belts.

1. Remove Drive Tracks (See CHANGING DRIVE TRACKS).
2. Place the cleaner on a non-abrasive surface and turn cleaner upside down. Remove Bottom Lid Assembly (Fig. 16).
3. Remove the Wheel Tube Retaining Rings (Fig. 17).
4. Locate and remove 4 screws (see Fig. 18) on Drive Motor side, which holds Side Plate in place.



TIP! We suggest using needle nose pliers to remove the Wheel Tube Retaining Rings.

NOTE: Before removing the screws, notice how the Drive Belts, Drive Pulley, Stepped Sleeve Rollers, Small Rollers and Bushings are positioned for re-assembly (Page 13; Fig. 19 a-b)

5. Remove old Drive Belts and replace them with new Drive Belts, being careful to properly position the replacements: *One Belt from the Drive Pulley to the Front Wheel Tube and one from the Drive Pulley to the Rear Wheel Tube. The Belts must press against the thicker side of the Stepped Sleeve Rollers for proper tension* (Page 13; Fig. 19 a-b).
6. To re-assemble, reverse steps 5 through 2.



TIP! Please see Page 13 for Top View and Inside View of the Drive Belt Assembly (Figs. 19a-b)!

Figure 16

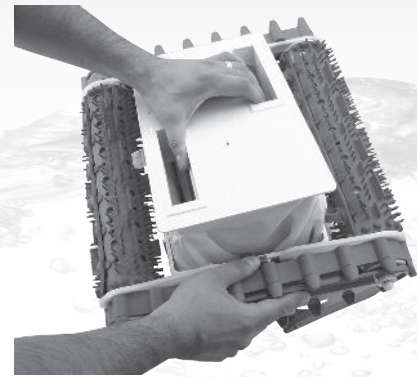

Figure 17

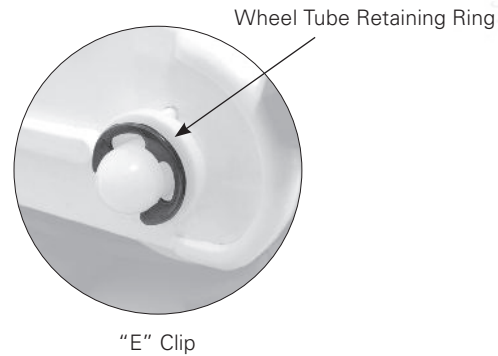
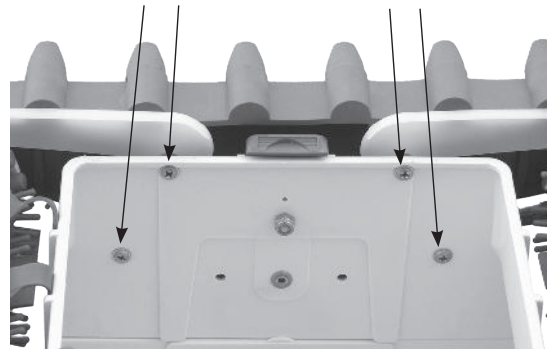

Figure 18

4 Screws on Drive Motor side



DRIVE BELT ASSEMBLY

*Figure 19a
Inside View*

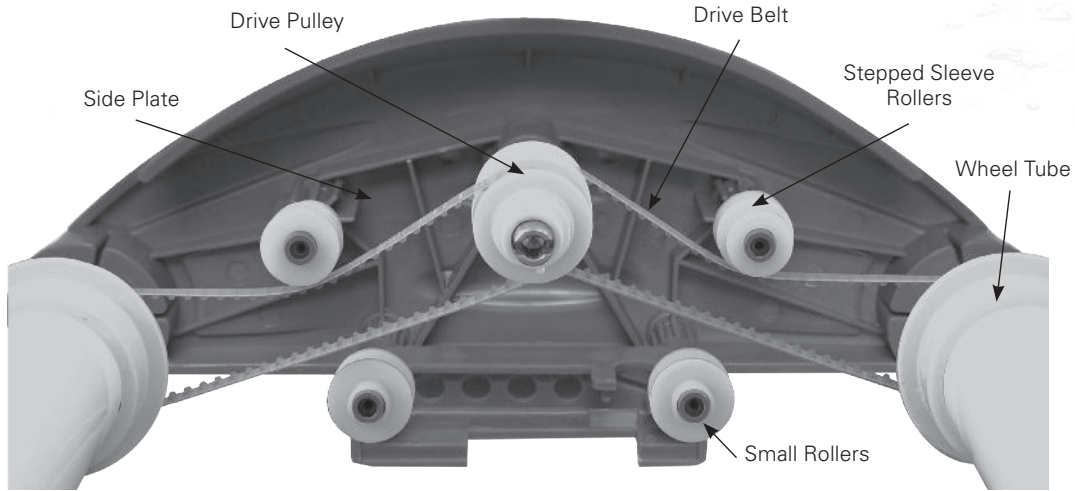

*Figure 19b
Top View*

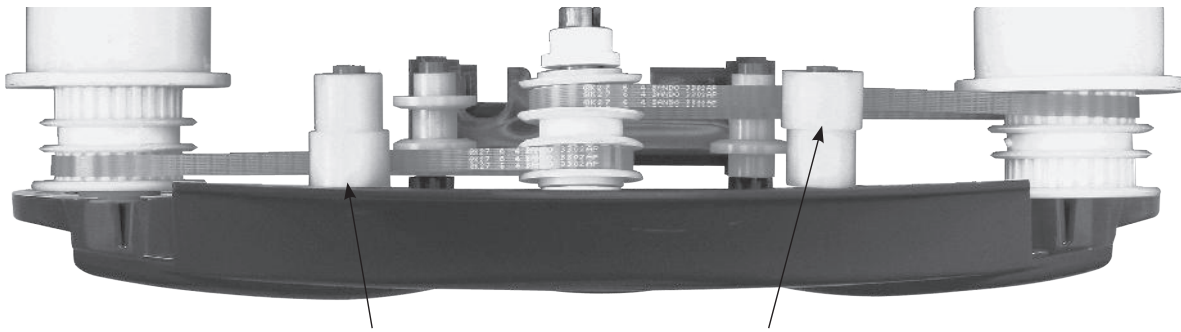

NOTE: When re-assembling be sure that the Drive Tracks are positioned so that they press against the thick side of the Stepped Sleeve Rollers.

CLEANER STORAGE

When not in use it is important that your cleaner, its Floating Cable and Power Supply are properly stored in a clean and dry area, away from direct sunlight, protected from below freezing temperatures and exposure to chemicals and their fumes (i.e. chlorine). This will help prevent any unnecessary wear or damage to your cleaner or its components. Prior to storing your cleaner, thoroughly clean your Filter Bag and dry off your cleaner. Ensure that its Floating Cable is untangled, not twisted nor in a figure eight, but rather coiled either around your cleaner's body or in large circular loops and positioned under your cleaner. Be sure to rest your cleaner on its side so that its Brushes do not get flat spots.

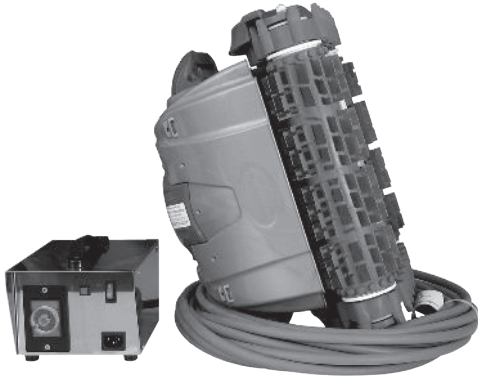

Correct



Incorrect

(do not place cleaner on top of power supply)



Incorrect

(do not coil cable in a figure 8 configuration)

PREPARING YOUR CLEANER FOR SHIPPING

In the event that you should have to send your cleaner in for repair, you must package the cleaner properly to ensure it reaches the repair facility safely and without incurring damage during transport. This will delay your repair turnaround time and require you to contact your shipper directly to dispute damages.

NOTE: A log of all information from your contact with the Authorized Service Center (i.e. RMA, name, dates, cleaner model and serial number, etc.) should be kept with your operator manual and / or other important documents for your reference (See page 22: NOTES).

- 1 Ask the Service Center whether the Power Supply needs to accompany the cleaner. If yes, the Power Cord should be coiled (Fig. 20a) and the Power Supply should be entirely well wrapped in bubble-wrap or equivalent protective material (Fig. 20b). The Power Supply should be positioned in the center of the base of the shipping box and the shipping box base must be firmly sealed (Fig. 20b).

Figure 20a



Figure 20b



- 2** The cleaner's Floating Cable should be coiled and encircled around the Power Supply located at the base of the shipping box (Fig. 21).

Figure 21



- 3** A protective barrier (preferably thick cardboard) should be placed on top of the Floating Cable and Power Supply (Fig. 22).

Figure 22



- 4** Your cleaner should be completely wrapped in bubble-wrap or equivalent protective material. The protected cleaner should be positioned in the center at the base of the protective barrier that is shielding the cleaner from the Power Supply and the Floating Cable underneath. Insulated protective material like bubble-wrap should be placed between the cleaner and the shipping box at walls and top to secure the cleaner and around shipping during transit (Fig. 23).

Figure 23



- 5** Include a copy of all information obtained during your contact with the Authorized Service Center, including your contact information and cleaner's serial number in an envelope (Fig. 24). A copy of the information relevant to the current technical issue should be sent in the packaging with your cleaner in an envelope. Please include a letter indicating the following:

- Technical issue
- Troubleshooting procedures that you completed
- Who you spoke with, when and what was determined
- Your contact information (***name, email, phone number, address cleaner model name and serial number***)

Figure 24



IMPORTANT: Keep a copy of your shipping information for tracking purposes! See page 22.

TROUBLESHOOTING GUIDE

~ SUMMARY ~

The most common troubleshooting issues are presented in this summary. Should you wish a more detailed description of a procedure or have other troubleshooting issues please refer to the In Depth Troubleshooting Guide on pages 18-21.



WARNING: Before performing any troubleshooting maintenance procedures on your cleaner, it should be disconnected from the Power Supply (transformer) and the Power Supply should be unplugged from the electrical outlet to prevent the possibility of personal injury or damage to the cleaner!

1. PUMPS WATER, BUT DOES NOT MOVE OR MOVES SLOWLY

- A. Remove any foreign matter that may be obstructing Drive Track (Page 3; Fig. 1, 13) movement.
- B. Check Drive Belts and Drive Tracks (Pages 11-13). Make sure they have not slipped out of place and that they are not loose.
- C. With cleaner upside down on a soft surface (to protect from scratching its body) plug Power Supply in and turn it on for less than a minute to observe whether the Drive Pulley (Page 13; Figs. 19a-b) is turning. If it is not moving please visit your local Authorized Service Center.

2. MOVES BUT DOES NOT PICK UP DIRT AND DEBRIS (DOES NOT PUMP WATER)

- A. Clean the Filter Bag thoroughly (Page 8).
- B. Ensure that the Debris Intake Port Flaps (Page 4; Fig 3, 12d) on the underside of the Bottom Lid Assembly (Fig 3) are free to open and close.
- C. Remove Outlet Top (Page 10; Figs. 12b-c) by removing screws located at the top and clean any hair or debris on or around the propeller (see Page 10 PROPELLER CARE). When reassembling the Outlet Top, BE CAREFUL NOT TO OVER-TIGHTEN THE SCREWS.

4. FALLS OR FLIPS BACKWARD OFF OF THE WALL

- A. Make sure Pump Motor (Page 3; Fig. 1, 7) is working properly and that the Propeller is not being slowed or stopped due to debris caught around it. Please refer to PROPELLER CARE (Page 10; Figs. 12a-c).
- B. Check Scrubbing Brushes (Pages 10-11, SCRUBBING BRUSHES CARE AND REPLACEMENT) for wear.
- C. Remove Flotation (see Page 9, FLOTATION).

5. DEBRIS COMES OUT OF THE CLEANER WHEN REMOVING IT FROM THE POOL - BOTTOM LID ASSEMBLY (Page 4; Fig. 3) DOES NOT CLOSE PROPERLY

- A. Make sure Filter Bag is mounted properly onto the Bottom Lid Assembly (Page 8; Figs. 8 and 9a-b).
- B. Make sure Debris Intake Port Flaps on underside of your cleaner move freely to open and close (Page 4; Figs 3, 12d).
- C. Make sure Pump Motor (Page 3; Fig. 1, 7) is working properly and that the Propeller is not being slowed or stopped due to debris caught around it. Please refer to PROPELLER CARE (Page 10).

6. DOES NOT PUMP WATER OR MOVE, OR POWER SUPPLY (Page 4; Fig. 4) DOES NOT TURN ON

- A. Check to see if electrical outlet has power.
- B. Check the Fuse in the Power Supply (Page 4; Fig 4). If necessary, replace with the same type / amperage Fuse. If unsure as to Fuse type, please contact your Authorized Service Center.



WARNING: Before performing any troubleshooting maintenance procedures on your cleaner, it should be disconnected from the Power Supply (transformer) and the Power Supply should be unplugged from the electrical outlet to prevent the possibility of personal injury or damage to the cleaner!

- C. Make sure Floating Cable Plug (Page 5; Fig. 5a) fits tightly into Power Supply.
- D. First, unplug the Power Supply from the outlet! Then, using a cotton swab, dry any moisture within Fuse Holder (Page 4; Fig. 4) and on fuse itself.
- E. Check Floating Cable (Page 3; Fig. 2) and Power Supply Cable for possible cuts or damage.

7. DOES NOT CLEAN ENTIRE POOL (MISSES AREAS)

- A. Clean Filter Bag thoroughly (Page 8).
- B. Install Flotation to help the cleaner climb walls partially if it's not climbing (Page 9).
- C. Operate the cleaner several cycles (up to 7 hours each).

8. GETS STUCK ON, MAIN DRAINS, RETURN FITTINGS, LIGHTS, STAIRS OR IN CORNERS

- A. Check Scrubbing Brushes for wear (Pages 10-11 SCRUBBING BRUSHES and REPLACEMENT).
- B. Adjust Flotation (Page 9, FLOTATION).

9. POWER SUPPLY APPEARS TO SHUT OFF BEFORE COMPLETING A CLEANING CYCLE

- A. Unplug the Power Supply and check the Fuse. (Page 4; Fig. 4)

10. DOES NOT SINK OR FLOATS AWAY FROM THE WALL

- A. Remove any additional flotation and trapped air (Page 6, CLEANER START POSITION).
- B. Check for squeaking or grinding.

TROUBLESHOOTING GUIDE

~ IN DEPTH ~



IMPORTANT: Before performing any troubleshooting maintenance procedures on your cleaner, it should be disconnected from the Power Supply (transformer) and the Power Supply should be unplugged from the electrical outlet to prevent the possibility of personal injury or damage to the cleaner.

PUMPS WATER, BUT CLEANER DOES NOT MOVE OR MOVES SLOWLY

Remove the cleaner from the pool and place it upside down (on a non-abrasive surface so that it won't become scratched or scuffed) and *unplug it from the Power Supply*.

1. Check for and remove any debris such as hair, string, or leaves that may be obstructing the free movement of the Drive Pulley, Drive Belts or Drive Tracks (Page 3; Fig. 1, 13).
2. Check that the Drive Belts and Drive Tracks (Pages 11-13) are properly aligned and are taut (see Page 13). Adjust or replace if necessary.

Then, plug the cleaner into the Power Supply, grab the Handle, lift your cleaner off the ground and turn it on outside the water while still upside down. Allow the cleaner to run a maximum of 1 minute to check the following:

3. Check that the Drive Pulley (Page 13; Figs. 19a-b) is turning. If it is not, grip one Wheel Tube with both hands and rotate it forward and reverse to see if the Drive Motor (Pages 3; Fig. 1, 8), to which the Drive Pulley is connected, loosens and begins to operate correctly.

If you have checked all of the options offered and the problem has not been corrected then please visit your local Authorized Service Center.

MOVES BUT DOES NOT PICK UP DIRT AND DEBRIS (DOES NOT PUMP WATER)

1. Turn off the Power Supply, remove the cleaner from the pool, and unplug it from the Power Supply.
2. Clean the Filter Bag thoroughly (Page 8) so that the fine particles of dirt that get trapped within the fibers of the Filter Bag are removed. Keep in mind that the Filter Bag is capable of trapping particulates 20 times smaller than what the naked eye is capable of seeing. To ensure that the Filter Bag is not the issue and is cleaned, remove the Bag from your cleaner and operate it. If it now operates properly, then the Filter Bag requires a more thorough cleaning to remove the particulates from the fibers of the Bag.
3. Check the Intake Valve Flaps (Page 4; Fig. 3, 12d) on the underside of your cleaner. The Flaps should move freely to open and close. Clean and free the Valve Flaps if necessary.
4. Make sure Pump Motor (Page 3; Fig. 1, 7) is working properly and that the Propeller is not being slowed or stopped due to debris caught around it. Please refer to PROPELLER CARE (Page 10).
5. Using a screwdriver, remove the screws that secure the Outlet Top to the body (Page 10; PROPELLER CARE) and inspect the Propeller for clogs, hair or other debris which may keep it from spinning freely. If the Pump is operating properly replace the Outlet Top (Page 10; Figs. 12b-c). Be careful not to over tighten and "strip" the screws. If it appears to be frozen and no debris is blocking its movement, or if the Propeller moves freely when spun manually but not when the cleaner is turned on, or if the propeller is loose and wobbles when spun manually, *please visit* your local Authorized Service Center.
6. Check the operation of the Pump Motor (Page 3; Fig. 1, 7). While your cleaner is on in the pool, hold your cleaner by its Handle (Page 8; Fig. 7b) so that its Outlet Top (Page 10; Figs. 12b-c) protrudes just slightly out of the water. Look to see that water is gushing out from the Outlet Top.

FALLS OR FLIPS BACKWARDS OFF WALLS OR STAIRS

Clean Filter Bag (Page 8, CLEANING AND CHANGING THE FILTER BAG).

Remove Flotation (Page 9, FLOTATION): Remove Flotation one by one until proper buoyancy is returned. Be sure to always submerge your cleaner and holding its Handle turn upside down to remove any air that may be trapped within the cleaner's body. Careful removal of air trapped in the housing is critical to ensure natural balancing of your cleaner (Page 6; Step 2, CLEANER START POSITION).

Check the operation of the Pump Motor

Please refer to the Troubleshooting section titled: *MOVES BUT DOES NOT PICK UP DIRT AND DEBRIS*

If this situation persists, *please visit* your local Authorized Service Center.

DEBRIS COMES OUT OF THE CLEANER WHEN REMOVING IT FROM POOL (BOTTOM LID DOES NOT CLOSE PROPERLY)

Filter Bag

Ensure that the Filter Bag is properly mounted on the Wire Bag Support Frame (Page 8; Figs. 9a-b). The Filter Bag's small Label on the elastic edge should be on the outside of the bag and positioned at the center of either long side of the Bottom Lid Assembly plastic. Stretch the elastic bottom over each Wire and slide the Filter Bag down until the Filter Bag reaches the Bottom Lid plastic. At that point the Filter Bag's elastic bottom should be stretched over the plastic lips located on each short side of the Bottom Lid Assembly, and will hold the Filter Bag in place. Pull the Filter Bag top corners into each of the top 4 corners of the Wire Frame. Insert the Bottom Lid into the bottom of the cleaner. Be sure that the Filter Bag's fabric is not interfering with the locking of the Lock Tabs (Page 8; Fig 8). Be sure that each of the Lock Tabs are "Locked" closed.

Debris Intake Port Flaps (Page 4; Fig. 3, 12d)

Check that the Intake Valve Flaps on the underside of your cleaner (in the Bottom Lid Assembly / Page 4; Fig. 3) move freely to open and close. Clean Flaps if necessary.

Lock Tabs (Page 8; Fig 8)

Check that the Lock Tabs are not warped. They should be straight and aligned with the cleaner's body. If they are warped then replacement Lock Tabs are available for purchase through your Authorized Dealer.

DOES NOT PUMP WATER OR MOVE, OR POWER SUPPLY DOES NOT TURN ON

It is unlikely that both Motors (Drive Motor and Pump Motor; Page 4; Figs.1, 7 and 8) are experiencing mechanical problems. In most cases the issue lies with something that is hindering the flow of electricity from the electrical outlet to the Power Supply (Page 4; Fig. 4) or through the Floating Cable (Page 3; Fig. 2) to the cleaner itself. To locate and resolve where electrical flow is being hindered check the following:

Electrical Outlet & Connections

Make sure that the Power Supply is firmly plugged into a grounded electrical outlet which has power. To test the outlet, plug in another electrical instrument that you know works to the outlet.

Check that the Floating Cable is securely plugged into the Power Supply.

Power Supply and Fuse (Page 4; Fig. 4)

1. Check that the Power Switch is pressed upwards to the "ON" position.
2. Switch the Power Supply "OFF" and "ON" several times, allowing approximately 30 seconds between each "ON" and "OFF".
3. Unplug the Power Supply from the electrical outlet. Check that the Fuse (Page 4; Fig. 4) in the Power Supply's Fuse Holder appears operational. If the Fuse appears burned out, then replacement Fuses are available for purchase through most major electronic supply stores, including your Authorized Dealer.
4. After unplugging the Power Supply from the electrical outlet, use a cotton swab to dry all sides of the Fuse and Fuse Holder (inside and out). Reinsert Fuse and plug in and start Power Supply.

Cable Assembly (Page 3; Fig. 2)

With the Power Supply unplugged, check the Power Supply Cable (Page 4; Fig. 4, 15f) and the Floating Cable (Page 3; Fig. 2) for cuts or damage. If you detect damage to either Cable, *please visit* your local Authorized Service Center.

DOES NOT CLEAN ENTIRE POOL (MISSES AREAS)

Your cleaner is designed to clean the pool many times over within its recommended cleaning cycle by moving along the width of the pool (side wall towards side wall), not the length.

Your cleaner operates by crossing over 50% of the floor's width, stop and reverse on an angle or arc to move back towards the original side wall. Once the cleaner reaches the original wall it will reverse and repeat this process with varied distances across the width of the pool. It will only partially climb the original wall every 4 times. (See also Pages 7; CLEANING PATTERN)

If large portions of the pool are missed, then please check the following:

1. Be sure that the Power Supply (Page 4; Fig. 4) and is located in the center of either one of the long sides of the pool (Page 6; Fig. 6b). This will allow optimum use of the Floating Cable's length (Page 6; SETTING UP THE POWER SUPPLY). Make sure the Floating Cable is untangled and spread out on the water's surface and that there is adequate Cable length for cleaner to reach all areas of the pool.
2. The Fine Filter Bag may remove particulates 20 times smaller than what is visible to the naked eye. Thoroughly clean the Filter Bag to remove it of the fine particles embedded within the Bag fibers (See Page 8, CLEANING AND CHANGING THE FILTER BAG). **To test if the Filter Bag is inhibiting the cleaner's performance, simply remove the Filter Bag from the Bottom Lid Assembly (Page 8; Fig. 8).** Then re-insert the Bottom Lid Assembly into the cleaner and operate the cleaner without the Bag. If the cleaner pumps water strongly, and climbs the walls properly, then you have confirmed that the Filter Bag requires a thorough cleaning.
3. Check that the Pump Motor (Page 3; Fig. 1, 7) is operating. Please refer to the Troubleshooting Guide (In Depth) section titled MOVES BUT DOES NOT PICK UP DIRT AND DEBRIS (Page 18).
4. Remove obstructions from your pool. Objects protruding from walls may impede the left/right movement of your cleaner when it is at the waterline causing the cleaner to remain in one or two sections while missing others. For optimal performance, it is recommended to remove objects from the pool walls when operating your cleaner. If some objects, such as ladders, can not be removed during your cleaner's cleaning cycle, place the cleaner in each of the 'separate' portions of the pool allowing each portion separate complete cleaning cycles. In this case place the Power Supply at the farthest points of the pool during each cleaning cycle.
5. Check that the Drive Belts and Drive Tracks are properly aligned and are taut (Pages 11-13). Adjust or replace if necessary.
6. Check for excessive wear of the Scrubbing Brushes, which provide traction for climbing and replace if necessary (Pages 10-11; SCRUBBING BRUSHES and REPLACEMENT).

NOTE: Rubber Brushes begin to stiffen in water less than 70°F which lessens their ability to climb and move.

7. Add Flotation (Page 9).
8. With your hand, feel the lower surface of your pool walls just above the floor. In rare instances the pool walls may be slippery due to either algae or a newly polished finish and may require manual cleaning/brushing first.

Please see a water chemistry specialist, such as your Authorized Dealer, for proper treatment of your algae type. If it is suggested to "Shock" your pool, and then manually brush and vacuum the dead algae from all surfaces to remove the bulk of the algae from the pool, please know that if you use your cleaner to remove the dead algae then the Filter Bag will clog quickly, requiring several cleaning cycles and many through Filter Bag cleanings. Additionally, your cleaner's Brushes will become covered with algae and will require that they be thoroughly cleaned to ensure traction for further use.

9. If you use a non-chlorine coagulating solution (i.e. Baquacil®) to clean your pool a clear slick film may form along your pool's walls impeding the cleaner's ability to climb. We suggest adding 225 to 300 parts per million of Calcium Hardener to your pool water to combat the film build-up.

GETS STUCK ON, MAIN DRAINS, RETURN FITTINGS, LIGHTS, STAIRS OR IN CORNERS

Your cleaner has approximately one inch of clearance between the floor and its underside. The Brushes (Page 16, SCRUBBING BRUSHES CARE AND REPLACEMENT) enable the cleaner to climb over most obstacles like main drains, return filters, lights, and pop-up, in-floor systems, and to climb up stairs in most pools. But, in some cases, the size or convex surface of some of these obstacles (i.e. lights, raised main drains) are too great and stop the cleaner from moving forward or reverse by catching on the underside of the cleaner.

Follow these recommendations to assist your cleaner with the following obstacles:

If necessary, you may reposition your Power Supply to the mid-point of either short side of your pool's width, always keeping the Power Supply at least 12 feet / 4 meters from the pool's edge, to allow adequate Floating Cable length to reach all areas of the pool (Page 6, Fig. 6b).

Main Drains

Contact an Authorized Dealer location to purchase a main drain guard, which will prevent your cleaner from becoming stuck on the Main Drain.

NOTE: The bottom step of a ladder may stop your cleaner from freely climbing and tilting 90° up the wall from the floor. This means the cleaner will remain in the forward mode, 'spinning its wheels', under the ladder, not allowing its internal incline sensors to detect the wall. Fortunately, your cleaner is equipped with safety timer that will automatically reverse your cleaner after a period of time.

Scrubbing Brushes (Pages 10-11)

Check that your Brushes are plush and not worn. Should they require replacement, replacement sets are available for purchase through your Authorized Dealer.

Incline Sensors

Always start your cleaner on a horizontal level surface with both Brushes touching the floor (Page 6, Step 2). Should your cleaner begin its cleaning cycle in an incline, the Incline Sensors within the Drive Motor may begin operating assuming that the incline angle is a level floor. When the cleaner does become level, the Incline Sensors will tilt and consider the floor to be the wall. This will offset its operation, resulting in insufficient cleaning due to remaining in forward or reverse positions for great lengths of time when not needed.

POWER SUPPLY APPEARS TO SHUT OFF BEFORE COMPLETING A CLEANING CYCLE

1. Unplug the Power Supply and check the Fuse (Page 4; Fig. 4) to see if it is blown. If the Fuse appears burned out, then replace it with the same type / amperage Fuse.
2. If your cleaner's Power Supply is connect to an external timer, check to make sure that the external timer source is set for the desired cleaning cycle timeframe.

DOES NOT SINK OR FLOATS AWAY

Remove any additional Flotation (Page 9, FLOTATION)

Clean the Filter Bag thoroughly as it may trap air (Page 8, CLEANING AND CHANGING THE FILTER BAG)

Remove any trapped air (Page 6, CLEANER START POSITION)

If you have previously added any (combination) of the Flotation (Page 9) provided into your cleaner, to assist its buoyancy, it is suggested that you remove the devices one-by-one until proper buoyancy is restored and the noise has lessened.

Squeaking

The cleaner is composed from plastic, rubber and stainless steel components which may squeak as the cleaner operates. Apply non-water soluble grease or oil to component contact points [i.e. where the Wheel Tube meets the Side Plate (Page 13, Figs. 19a-b), where the Drive Pulley meets the Bushing (Page 13; Figs. 19a-b), etc.] to assure the smooth movement of these parts and reduce squeaking.

Grinding

Check Drive Belts and Drive Tracks (Pages 11-13) for proper tension and alignment. Adjust or replace if necessary.

MAKE A RECORD FOR FUTURE USE

MODEL _____

PURCHASE DATE _____

PLACE PURCHASED _____

SERIAL NUMBER _____

NOTE: Serial number can be found on the warranty card, the packing carton and your cleaner.

QUESTIONS?

Contact the Retailer you purchased your cleaner from

ADDITIONAL NOTES: